

Enabling Nanoscale Advances



Park NX7

The affordable choice for the first step AFM research with the latest NX components





Park NX7

The most affordable research grade AFM with flexible sample handling

Park NX7 has all the state-of-the-art technology you have come to expect from Park Systems, at a price your lab can afford. Designed with the same attention to detail as our more advanced models, NX7 allows you to do your research on time and within budget.

Accurate XY Scan by Crosstalk Elimination

- Two independent, closed-loop XY and Z flexure scanners
- Flat and orthogonal XY scan with low residual bow
- Accurate height measurements without any need for software processing

The Most Extensible AFM Solution

- The most comprehensive range of SPM modes
- Advanced nanomechanical measurement modes are supported as default enabled by NX electronic controller
- The best option compatibility and upgradeability in the industry

User Experience-Driven Software and Hardware Features

- Open side access for easy sample or tip exchange
- Easy, intuitive laser alignment with pre-aligned tip mount
- Park SmartScan™ - AFM operating software versatile enough to empower both novices and power users alike toward great nanoscale research

Park NX7

AFM Technology

Flat Orthogonal XY Scanning without Scanner Bow

Park's Crosstalk Elimination scanner structure removes scanner bow, allowing flat orthogonal XY scanning regardless of scan location, scan rate, and scan size. It shows no background curvature even on flattest samples, such as an optical flat, and with various scan offsets. This provides you with a very accurate height measurement and precision nanometrology for the most challenging problems in research and engineering.

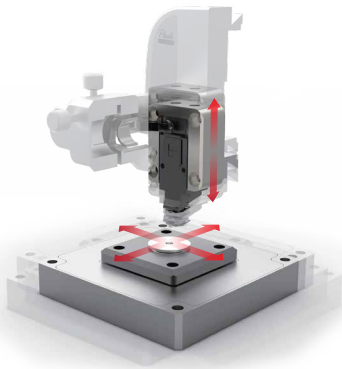

Decoupled XY and Z Scanners

The fundamental difference between Park and its closest competitor is in the scanner architecture. Park's unique flexure based independent XY scanner and Z scanner design allows unmatched data accuracy in nano resolution further improved with NX AFM Head (Z scanner) powered by NX AFM electronic controller.

Accurate Surface Measurement

"Flat" sample surface as it is!

- Low residual bow
- No need for software processing
- Accurate results independent of scan location
- Less than 2 nm of out-of-plane motion with the NX electronic controller

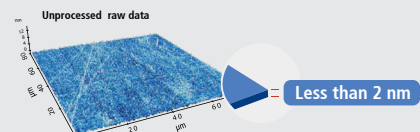
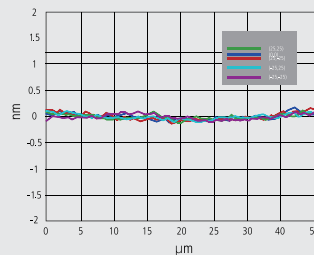

Industry Leading Low Noise Z Detector

Park AFMs are equipped with the most effective low noise Z detectors in the field, with a noise of 0.02 nm over large bandwidth. This produces highly accurate sample topography and no edge overshoot. Just one of the many ways Park NX series saves you time and gives you better data.

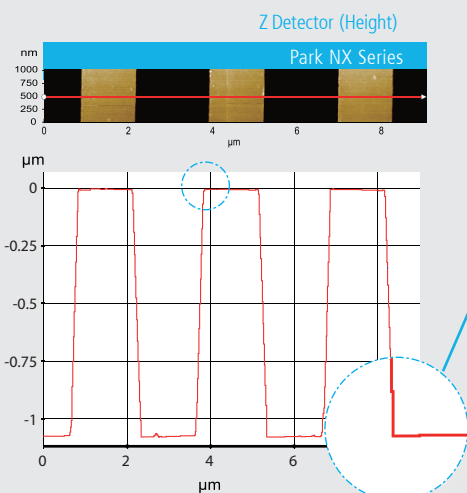

No creep effect

Accurate Sample Topography Measured by Low Noise Z Detector

- Uses low noise Z detector signal for topography
- Has low Z detector noise of 0.02 nm over large bandwidth
- Has no edge overshoot at the leading and trailing edges
- Needs calibration done only once at the factory

Sample: 1.2 μm Nominal Step Height
(9 μm x 1 μm, 2048 pixels x 128 lines)

True Non-Contact™ Mode

True Non-Contact™ Mode is a scan mode unique to Park AFM systems that produces high resolution and accurate data by preventing destructive tip-sample interaction during a scan.

Accurate Feedback by Faster Z-servo enables True Non-Contact AFM

- Less tip wear → Prolonged high-resolution scan
- Non-destructive tip-sample interaction → Minimized sample modification
- Maintains non-contact scan over a wide range of samples and conditions

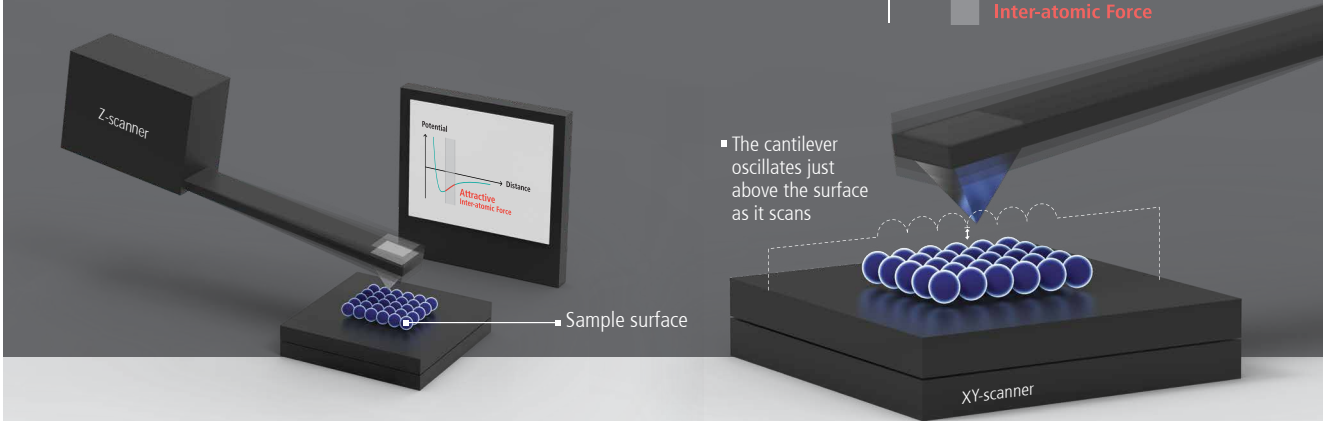
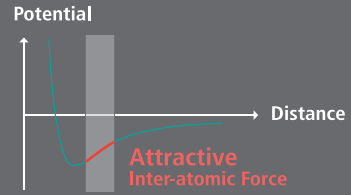

Unlike in contact mode, where the tip contacts the sample continuously during a scan, or in tapping mode, where the tip touches the sample periodically, a tip used in non-contact mode does not touch the sample.

Because of this, use of non-contact mode has several key advantages. Scanning at the highest resolution throughout imaging is now possible as the tip's sharpness is maintained. Non-contact mode avoids damaging soft samples as the tip and sample surface avoid direct contact.

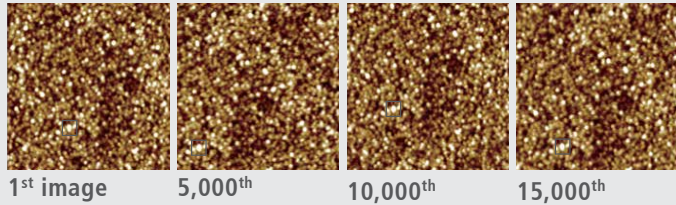
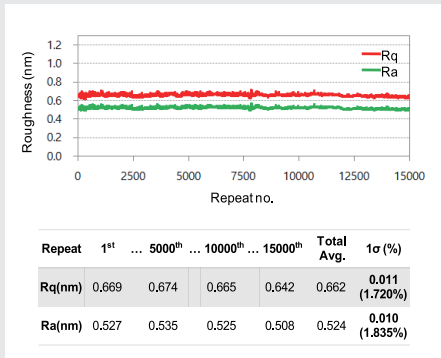

Furthermore, non-contact mode senses tip-sample interactions occurring all around the tip. Forces occurring laterally to tip approach to the sample are detected. Therefore, tips used in non-contact mode can avoid crashing into tall structures that may suddenly appear on a sample surface. Contact and tapping modes only detect the force coming from below the tip and are vulnerable to such crashes.

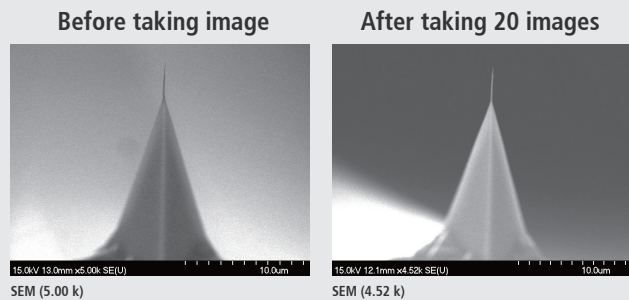
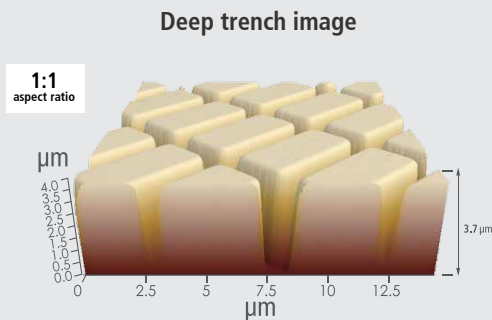

Park NX7

Why the world's most accurate small sample AFM is also the easiest to use

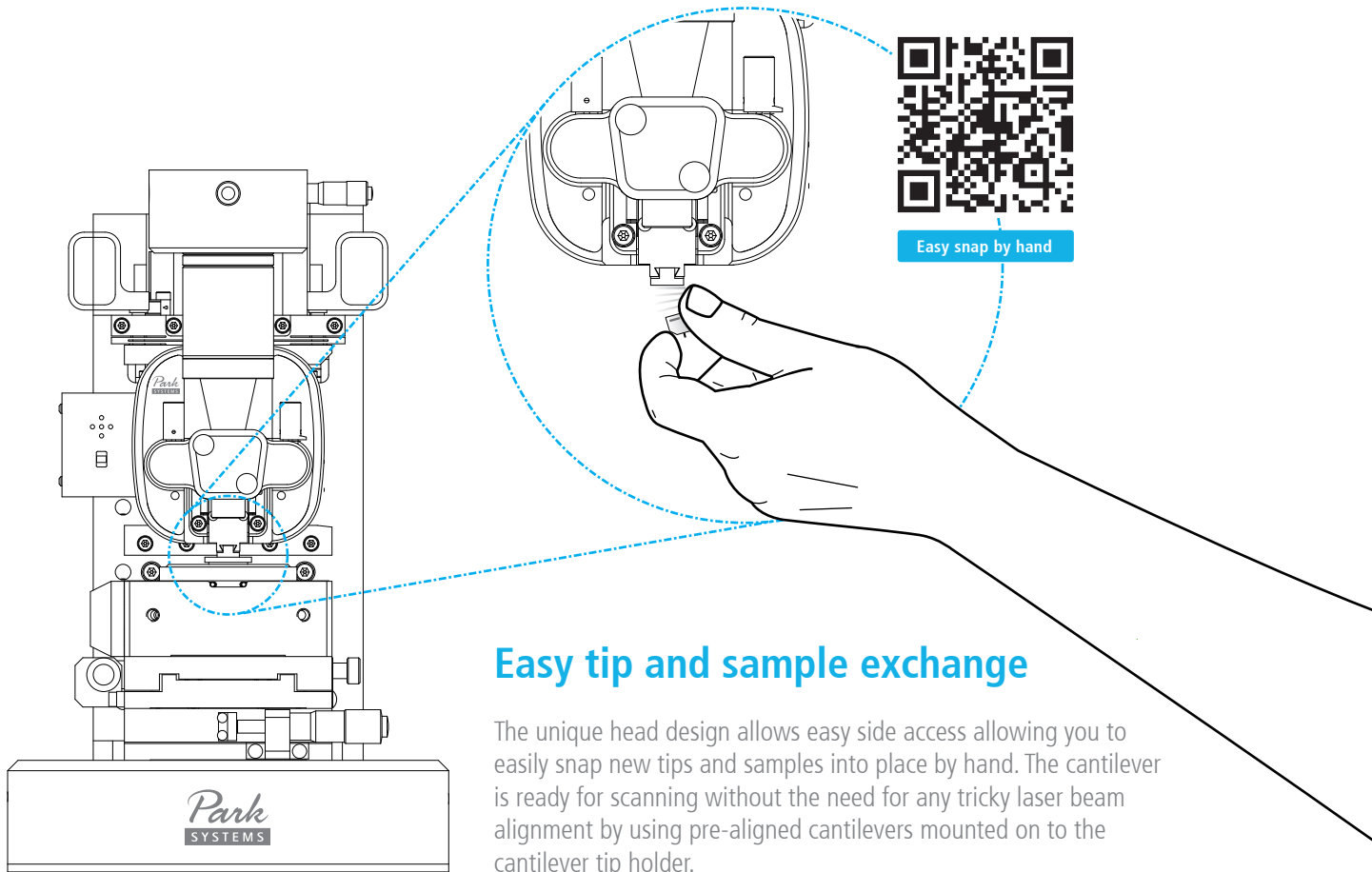

Easy tip and sample exchange

The unique head design allows easy side access allowing you to easily snap new tips and samples into place by hand. The cantilever is ready for scanning without the need for any tricky laser beam alignment by using pre-aligned cantilevers mounted on to the cantilever tip holder.

Easy, intuitive SLD beam alignment

With our advanced pre-aligned cantilever holder, the **SLD beam** is focused on the cantilever upon placement. Furthermore, the natural on-axis, top-down view allows you to easily find the SLD spot. Since the SLD beam falls vertically onto the cantilever, you can intuitively move the SLD spot along the X- and Y- axis by rotating two positioning knobs. As a result, you can easily find the SLD and position it onto the position-sensitive photodiode using our operation software's beam alignment user interface. From there, all you will need is a minor adjustment to maximize the signal prior to starting data acquisition.



The SLD beam is always focused on the cantilever upon replacement

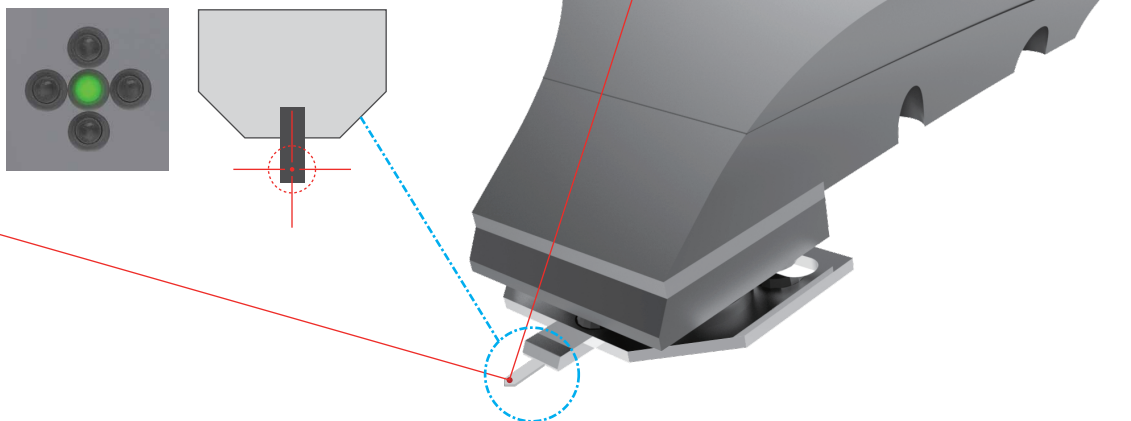

Park Atomic Force Microscopy Modes

Get the data you need with Park's selection of scanning modes

TOPOGRAPHY IMAGING				
	Contact	Non-Contact	Tapping	
ELECTRICAL / MAGNETIC PROPERTIES				
	Conductive AFM	PinPoint Conductive AFM	IV Spectroscopy	Photocurrent Mapping
	Scanning Tunneling Microscopy	Scanning Spreading Resistance Microscopy	Scanning Capacitance Microscopy	Electrostatic Force Microscopy
Kelvin Probe Force Microscopy	Piezoresponse Force Microscopy	Magnetic Force Microscopy	Tunable Magnetic Field MFM	
NANOMECHANICAL PROPERTIES				
	Force Distance Spectroscopy	PinPoint Nanomechanical	Force Modulation Microscopy	Lateral Force Microscopy
	Nanoindentation	Nanolithography	Nanomanipulation	
OTHER PROPERTIES				
	Scanning Thermal Microscopy	Scanning Ion Conductance Microscopy		● NOT AVAILABLE FOR THIS PRODUCT

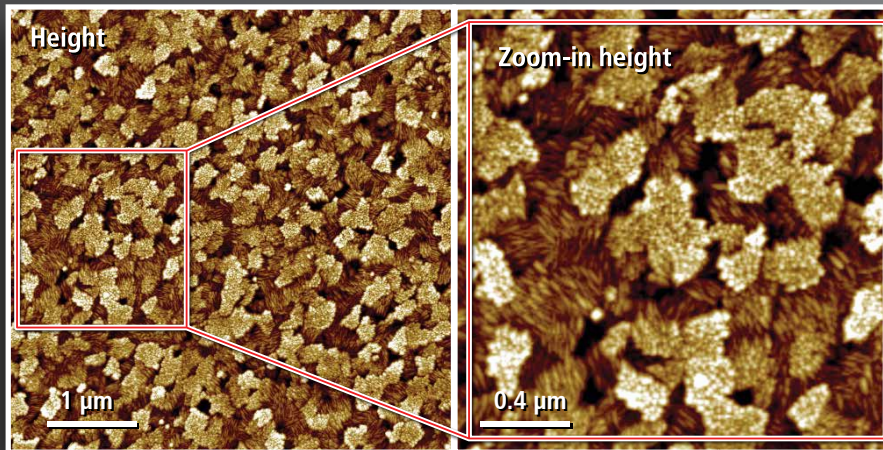

ITO coated Quarts chip

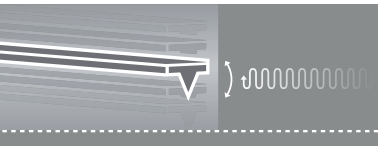

Scanning conditions

Scan Mode: Non-Contact
 Scan Size: 5 μm x 5 μm, 2 μm x 2 μm
 Cantilever: AC160TS (k= 26 N/m, f= 300 kHz)

Sample courtesy: Kee-Hyun Paik, Multerra Bio, Inc., US

F₁₄H₂₀ on Si; Work function

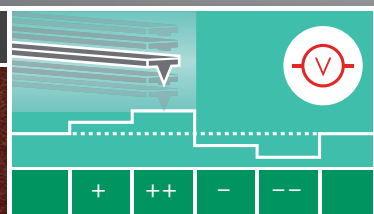
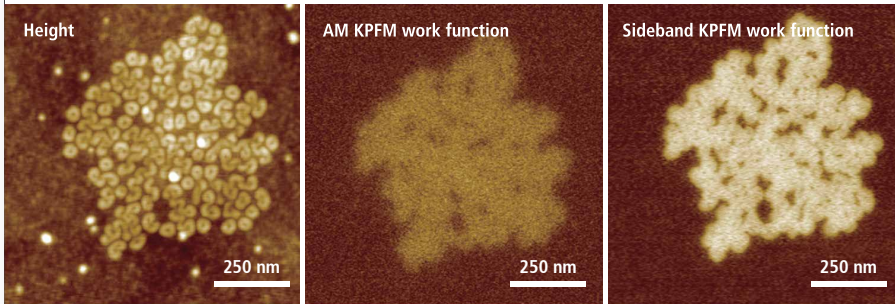

Scanning conditions

Scan Mode: KPFM
 Scan Size: 1 μm x 1 μm
 Cantilever: PPP-EFM (k= 2.8 N/m, f= 75 kHz)

The same image color scale was used for work function image comparison.
 Sideband KPFM shows the better image quality and quantitative results compared to AM KPFM

Margarines

Phase change of Margarine surface by temperature control

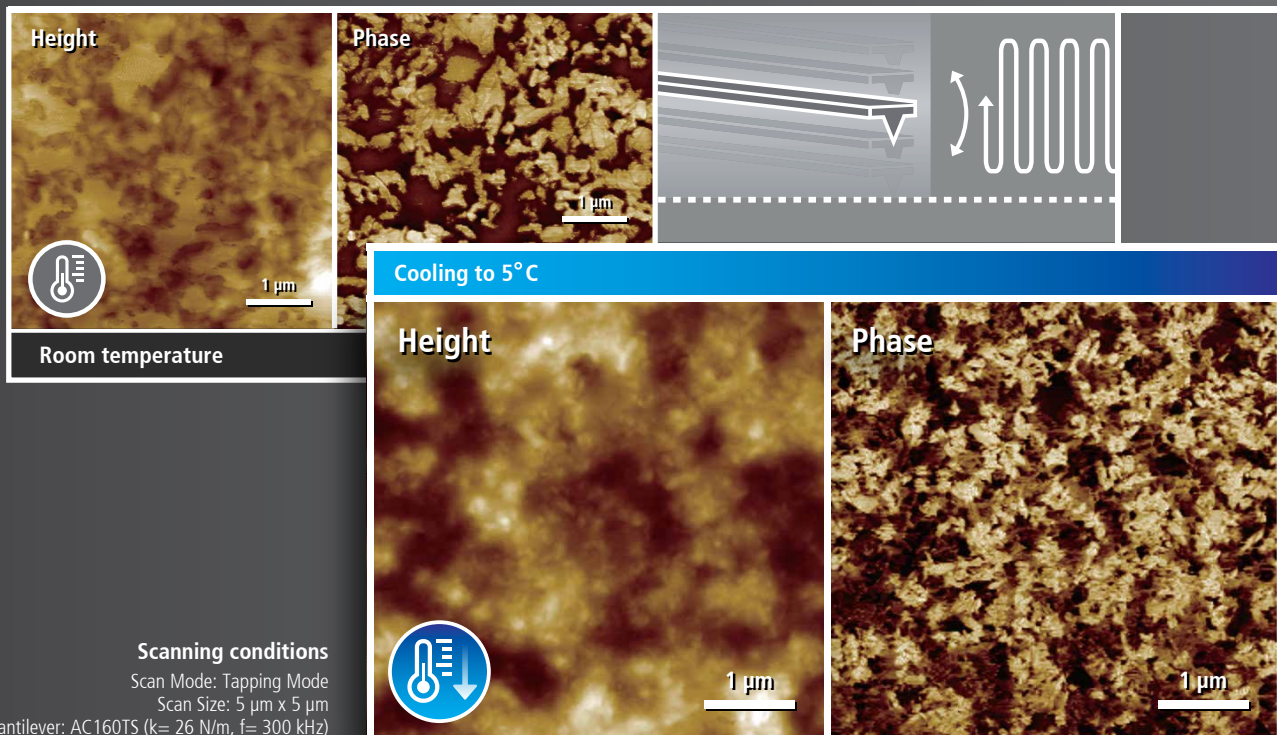

Room temperature

Cooling to 5°C



Scanning conditions
 Scan Mode: Tapping Mode
 Scan Size: 5 μm x 5 μm
 Cantilever: AC160TS (k= 26 N/m, f= 300 kHz)

Scanner	Z Scanner	XY Scanner	Stage	Z Stage	XY Stage	
	Flexure guided high-force scanner Scan range: 15 μm (optional 30 μm)	Single module flexure XY-scanner with closed-loop control Scan range: 50 μm \times 50 μm (optional 10 μm \times 10 μm or 100 μm \times 100 μm)		Z stage range: 26 mm	XY stage range: 13 mm \times 13 mm	
Vision	On-axis Optic with Vision Camera	Sample Mount	Sample Dimension	Electronics	Signal Processing	Integrated Functions
	Objective lens: 10x magnification Field-of-view: 480 μm \times 360 μm (with default 1.2 M pixel vision camera) 840 μm \times 630 μm (with optional 5 M pixel vision camera)		Sample size: Up to 50 mm Thickness: Up to 20 mm		ADC: 24-bit ADCs for X, Y, and Z scanner position sensor DAC: 20-bit DACs for X, Y, and Z scanner positioning	4 channels of flexible digital lock-in amplifier Spring constant calibration (Thermal method) Digital Q control
Options/Modes	Topography Imaging	Magnetic Properties		Electrical Properties		Mechanical Properties
	<ul style="list-style-type: none"> Non-Contact Contact Tapping 	<ul style="list-style-type: none"> Magnetic Force Microscopy (MFM) Tunable Magnetic Field MFM 		<ul style="list-style-type: none"> Conductive AFM (C-AFM) I/V Spectroscopy Kelvin Probe Force Microscopy (KPFM) KPFM with High Voltage Scanning Capacitance Microscopy (SCM) Scanning Spreading-Resistance Microscopy (SSRM) Scanning Tunneling Microscopy (STM) Photo Current Mapping (PCM) Electrostatic Force Microscopy (EFM) 		<ul style="list-style-type: none"> PinPoint Nanomechanical Mode Force Modulation Microscopy (FMM) Nanoindentation Nanolithography Nanolithography with High Voltage Nanomaniplulation Lateral Force Microscopy (LFM) Force Distance (Fid) Spectroscopy Force Volume Imaging
	Dielectric/Piezoelectric Properties	Chemical Properties				
	<ul style="list-style-type: none"> Piezoresponse Force Microscopy (PFM) PFM with High Voltage Piezoresponse Spectroscopy 	<ul style="list-style-type: none"> Chemical Force Microscopy with Functionalized Tip Electrochemical Microscopy (EC-AFM) 				
Software	Park SmartScan™	Park SmartAnalysis™		Accessories		
	<ul style="list-style-type: none"> AFM system control and data acquisition software Auto mode for quick setup and easy imaging Manual mode for advanced use and finer scan control 	<ul style="list-style-type: none"> AFM data analysis software Stand-alone design—can install and analyze data away from AFM Capable of producing 3D renders of acquired data 		<ul style="list-style-type: none"> Electrochemistry Cell Universal Liquid Cell with Temperature Control Temperature Controlled Stages 		

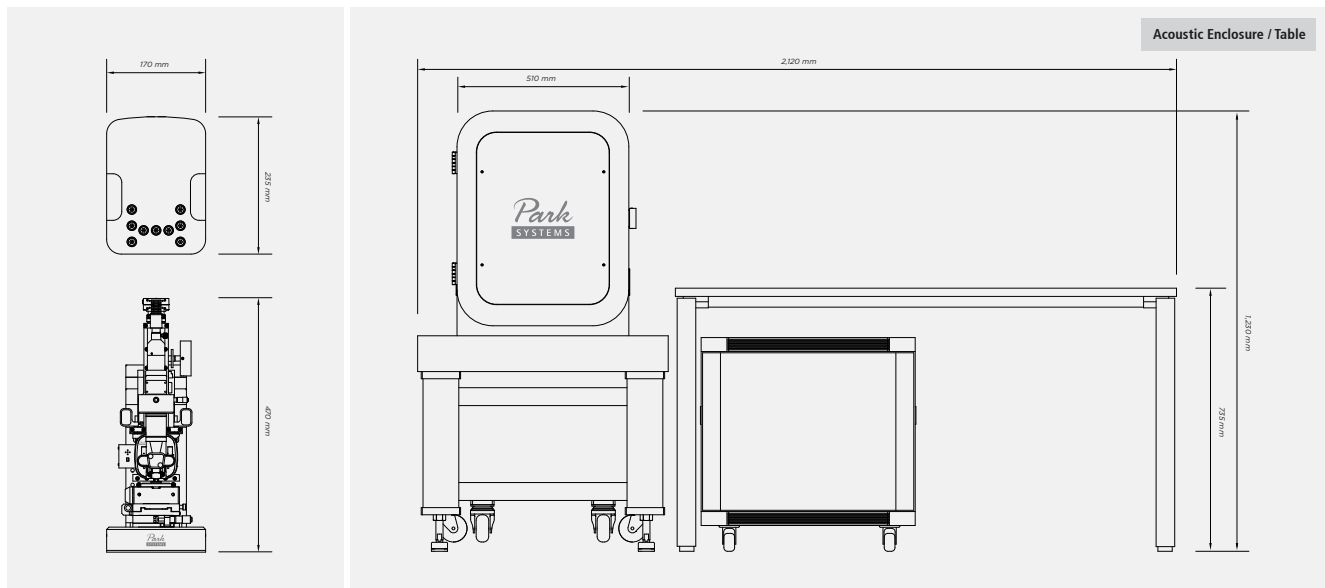

Committed to contributing to impactful science and technology

Park Systems Corporation is a leading manufacturer of nanoscale microscopy and metrology solutions that encompasses the atomic force microscopy, white light interferometry, infrared spectroscopy and ellipsometry systems. Its products are widely used for scientific research, nanoscale engineering, and semiconductor fabrication and quality assurance. Park Systems provides a full range of AFM products from desktop to fully automated systems with integrated robotic arms. Furthermore, its product line includes WLI AFM, Photo-induced Force Microscopy spectroscopy and ellipsometry systems for those in the chemistry, materials, physics, life sciences, and semiconductor industries. In 2022, Park Systems acquired and merged Accurion GmbH, a leader in high-end ellipsometry and active vibration isolation, to form Park Systems GmbH, Accurion Division.

Park Systems is a publicly traded corporation on the Korea Stock Exchange (KOSDAQ) with corporate headquarters in Suwon, Korea, and regional headquarters in Santa Clara, California, Mannheim, Germany, Paris, France, Beijing, China, Tokyo, Japan, Singapore, India, and Mexico. To learn more, please visit www.parksystems.com.

Park Systems Americas

+1-408-986-1110 (USA)
+52-55-7100-2354 (Mexico)

Park Systems Europe

+49 (0)-621-490896-50 (Germany)
+33 (0)-6-07-10-87-36 (France)
+44 (0)-115-784-0046 (UK&Ireland)

Park Systems GmbH - Accurion

+49-551-999600 (Germany)

Park Systems Japan

+81-3-3219-1001 (Japan)

Park Systems Greater China

+86-10-6254-4360 (China)
+886-3-5601189 (Taiwan)

Park Systems SE Asia

+65-6634-7470 (Singapore)

Park Systems Korea

+82-31-546-6800 (Republic of Korea)

Park Systems India

+91-96869 51464 (India)

Park Systems Corporate Headquarters

To learn more about Park Systems, please visit www.parksystems.com or e-mail inquiry@parksystems.com

KANC 15F, Gwanggyo-ro 109, Suwon 16229, Korea Tel.+82-31-546-6800

©2023 Park Systems Corp. All rights reserved. All products and features are subject to change.

All brand names and logos are trademarks of their respective companies.

No part of this publication may be reproduced or distributed without the express written permission of Park Systems Corp.

Park
SYSTEMS